

Microwave Reaction System for Sample Preparation

Multiwave PRO



Multiwave PRO

The Master of Sample Preparation Methods

The Multiwave PRO microwave reaction system delivers the sample preparation solutions you need to obtain excellent trace analysis results. Multiwave PRO masters high temperatures and provides comprehensive reaction control features. Its wide range of accessories allows digestion, leaching, oxygen combustion, solvent extraction, drying, evaporation, and UV digestion with one single system.

Superior trace elemental analysis begins with outstanding sample preparation. Even when using the best analytical equipment, you still need to optimize sample preparation conditions to obtain reliable measurement values. With over 40 years of experience, Anton Paar is your trusted resource.

Anton Paar manufactures outstanding instruments and also provides specialized application support and service including:

- Local dedicated application support specialists throughout the world
- On-site and local depot service options
- Application and demonstration laboratories throughout the world
- On-site demonstrations
- Extended user trainings and webinars
- Application literature and software upgrades from Anton Paar's website

Help when you need it

Depending on your needs, Anton Paar's team of academic chemists will create a method which fits your sample, your defined target elements and your analytical measuring technique.



► Convenient tool-free handling

Opening and sealing Multiwave PRO's rotors, vessels and sensors is quick and simple - just use your hands. This tool-free handling is unique to Anton Paar and simplifies this frequently repeated work step.

► Fit for pharma

Anton Paar supports you with an instrument-specific qualification package for Multiwave PRO. This package includes DQ, IQ, OQ and PQ, Risk Analysis, 21 CFR Part 11 checklist, Deviation List, Traceability Matrix and userSOP. The documentation fulfills the requirements of GMP, 21 CFR Part 11, GAMP 5, USP<1058> and covers all steps of a complete instrument qualification.

► Cooling: fast and quiet

The integrated forced-air cooling system with unique air gap design cools the vessels within minutes after heating cycles. This optimized cooling results in short process times and increased working life of key components. You do not need to handle hot pressurized vessels or connect an external cooling unit.

► Get in touch

The remote access via VNC allows you to easily operate Multiwave PRO from your computer, notebook or mobile phone.

► Safety without compromise

Numerous active and passive safety features protect the system, operator and surroundings in all situations.

Reaction Vessels

The reaction vessel is the heart of Multiwave PRO and the key to successful sample preparation.

Lip-type seal vessel

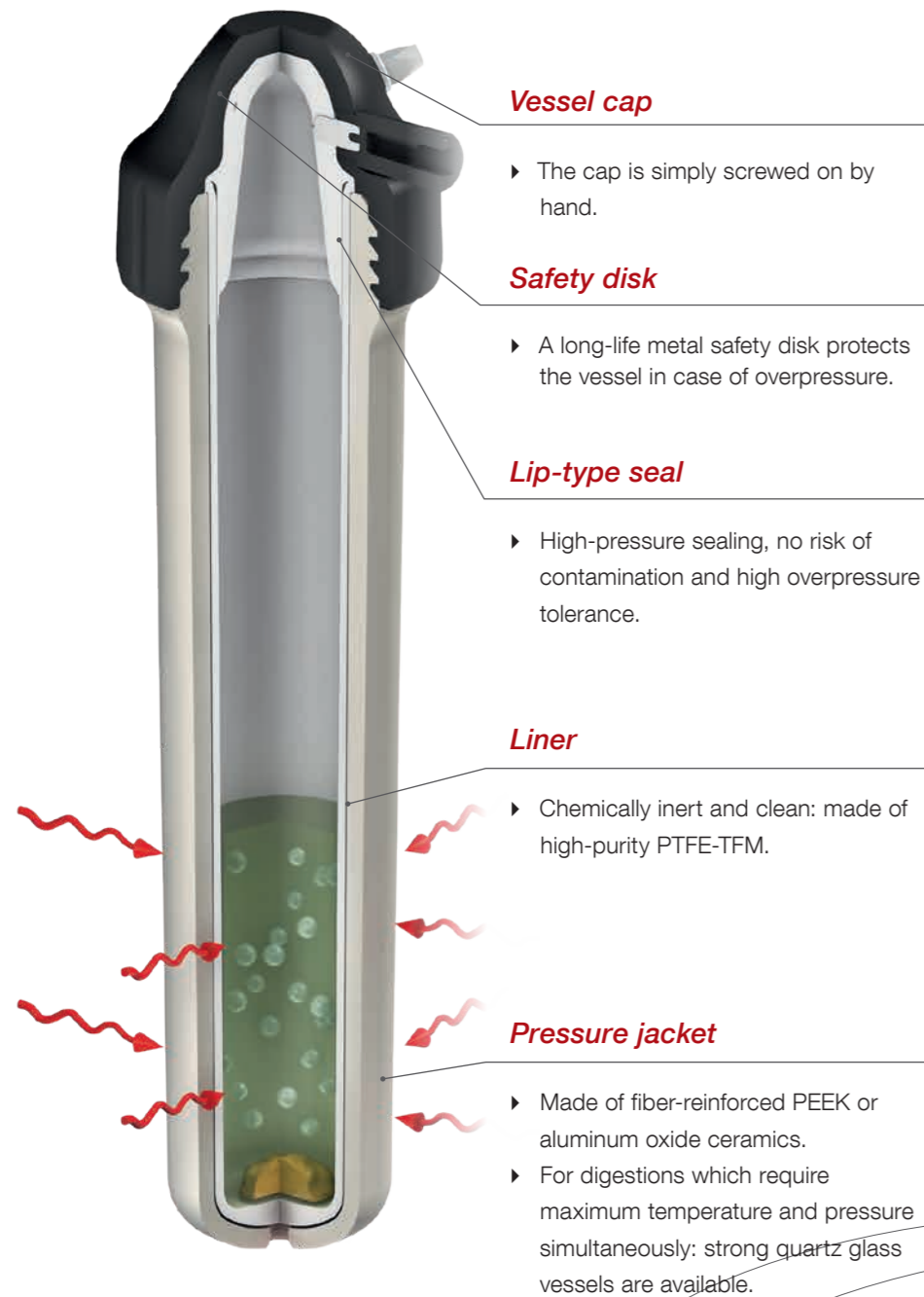

SMART VENT technology vessel

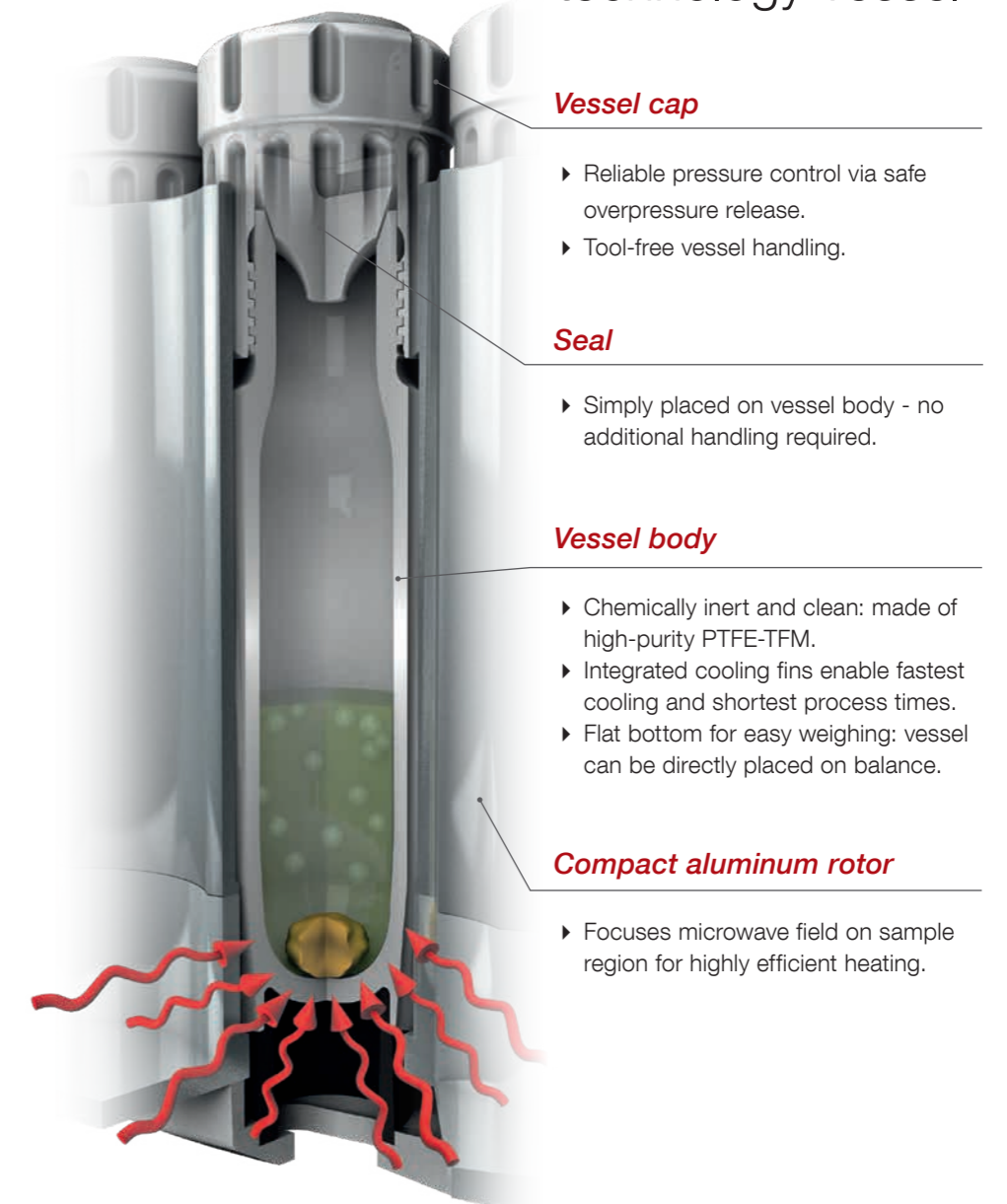

Acid Digestion Rotors

Technical Data



High-end

Use Rotor 8N to obtain the highest digestion quality. Rotor 8N masters temperatures up to 300 °C at pressures up to 80 bar for longer than 2 hours. Continuous pressure monitoring of all eight sample vessels ensures safe and precise reaction control, even with critical samples such as ceramics, semiconductors, ores, slags, ashes, plastics, oil, grease, coal and samples from refractories.

Workhorse

A selection of interchangeable pressure jackets, liners and seals makes it possible to digest a wide range of sample types, ranging from environmental samples to biological material, food to metals, alloys to geological materials. Even solvent extraction is covered. Due to the change from PEEK-GF (MF100) to ceramic pressure jackets (HF100) the pressure stability can be doubled.



Large sample amounts

Rotor 24HVT50 and Rotor 24HVT80 with vessels using SMART VENT technology offers you reliable pressure control and the possibility to safely digest samples with different reaction behavior in one run. The internal temperature of each vessel can be controlled without the need of any optional sensor. These rotors are ideal for the digestion of various kinds of samples, including food and biological samples, waste water and sludge, soil and sediments, EPA procedures, environmental samples, agricultural samples, cosmetic and pharmaceutical samples.

High batch size and large sample amounts

The 41-position rotor meets the demand for high sample throughput and eliminates your bottlenecks in sample preparation. The three-part vessel is designed for tool-free handling, simple cleaning, a long lifetime and low cost of consumables. Rotor 41HVT56 can be used for the digestion of various kinds of samples, including food and biological samples, environmental samples, agricultural samples, cosmetic and pharmaceutical samples.



Microsamples

Requiring up to 20 mg of sample and approx. 1 mL of acid, the 64-position rotor is unique for the large-scale digestion of microsamples, e.g. for biological materials.



Rotor	64MG5	41HVT56	24HVT50	24 HVT80	16MF100	16HF100	8NXF100	8NXQ80
No. of vessels	64	41	24	24	16	16	8	8
Reaction control	T in 16 positions	T in all positions	T in all positions				T and p in all positions	
Reaction control in a reference vessel	n.a.	n.a.	n.a.		p/T or p		T	
Vessels	MG5	HVT56	HVT50	HVT80	MF100	HF100	XF100	XQ80
Liner material	Glass (PTFE seal)	PTFE-TFM	PTFE-TFM	PTFE-TFM	PTFE-TFM	PTFE-TFM	PTFE-TFM	n.a.
Pressure jacket	n.a.	n.a.	n.a.	n.a.	PEEK-GF	Ceramic	Ceramic	Quartz
Volume	5 mL	56 mL	50 mL	80 mL	100 mL	100 mL	100 mL	80 mL
HF resistant	No	Yes	Yes	Yes	Yes	Yes	Yes	No

p... pressure, T... temperature, n.a. not applicable

Outstanding Sensor Technology

To obtain high-quality solutions and ensure safe operation, Multiwave PRO keeps pressure and temperature under control.

Wireless temperature measurement and control

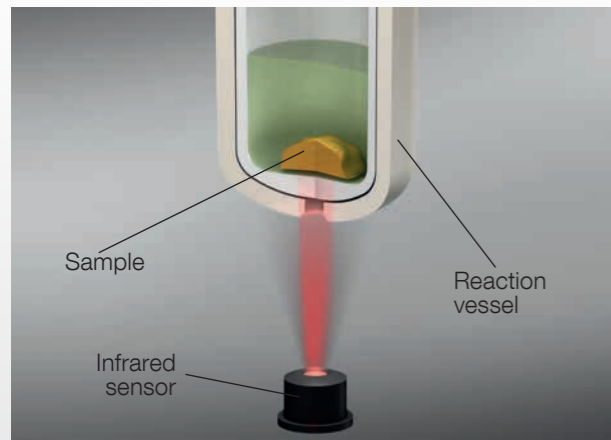

By monitoring the temperature of each vessel with an IR sensor

Safe and reliable digestion processes.

An infrared sensor measures the temperature at the base of each reaction vessel. If the temperature rises too high, Multiwave PRO reduces microwave power so that the temperature does not exceed a preset limit.

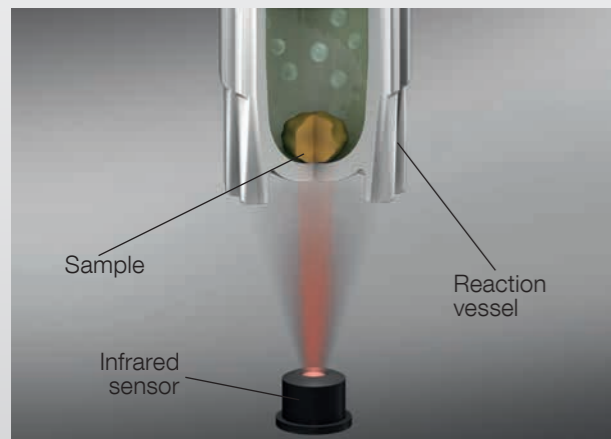

By controlling the internal temperature of each vessel

Precise control of digestion processes in each vessel.

Rotor 24HVT50, Rotor 24HVT80 and Rotor 41HVT56 vessels provide the internal temperature in each vessel without the need for an optional sensor. The digestion runs can be controlled based on different temperature control strategies. The hottest sample, the coldest sample or the average temperature of all samples can be used as references.

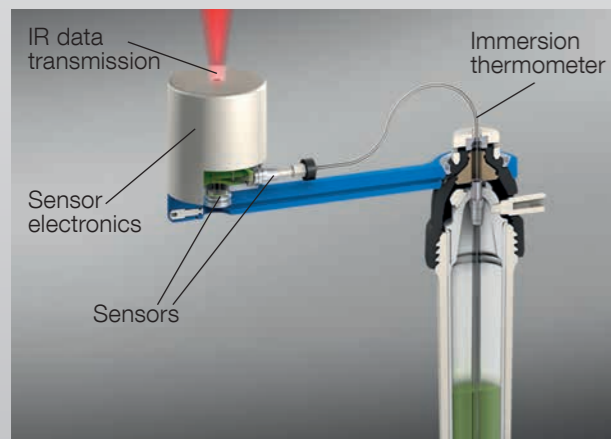

By measuring the temperature in a reference vessel

Quick and precise control, even of fast and spontaneous reactions.

A temperature sensor is integrated into one of the reaction vessels. With Multiwave PRO you can define temperature ramps, making it a valuable tool for digestion of unknown samples and method development.

Wireless pressure measurement and control

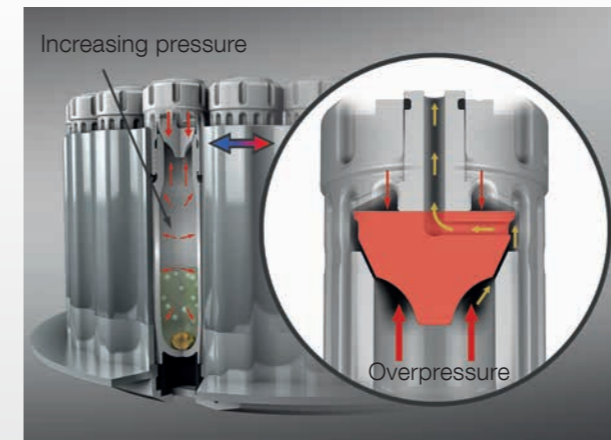

By controlled overpressure release

The result: precise pressure control in each vessel and significantly increased digestion temperatures.

Based on the SMART VENT technology used in the HVT vessels the overpressure is safely and reliably released. Thus the maximum temperature is not limited by the applied sample amounts. This concept permits the digestion of large sample quantities and the digestion of samples with different reaction behavior in one run.

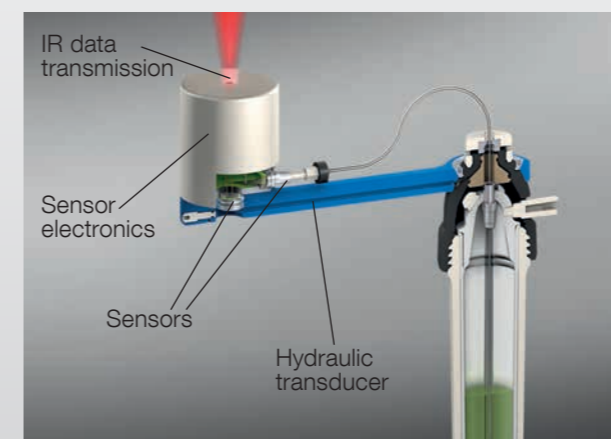

By measuring the pressure in a reference vessel

The result: quick and precise control, even of fast and spontaneous reactions.

A hydraulic pressure sensor with or without temperature sensor is integrated into one of the reaction vessels. It measures the pressure and the pressure increase rate every 20 milliseconds. If one of the preset limits is exceeded, the microwave power is immediately reduced and, if required, the cooling effort is increased.

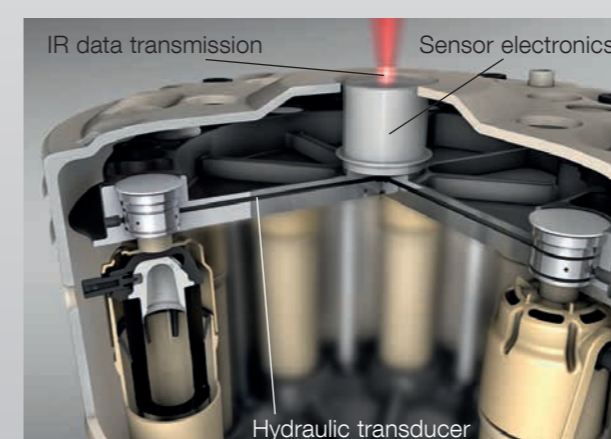

By measuring the pressure in all vessels every 20 milliseconds

The result: An extremely quick and simultaneous pressure measurement allows you to apply the highest possible temperatures for acid digestion.

Critical situations emerging from spontaneous reactions, for example, are intercepted due to the high frequency of pressure measurements. Multiwave PRO immediately reduces microwave power and the unwanted reaction is stopped before it leads to pressure release.

Special Solutions

Some samples require special treatment. Multiwave PRO provides unique methods which are efficient alternatives to digestion.

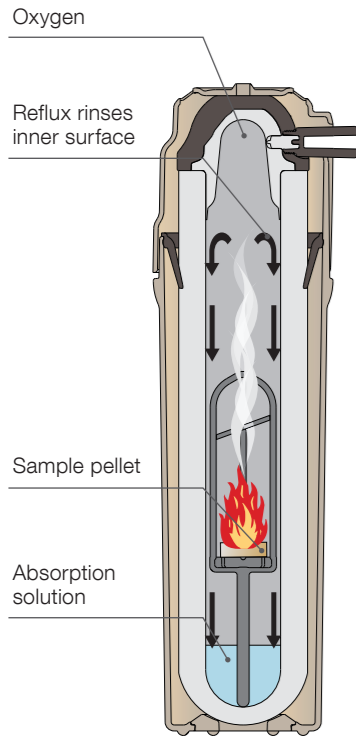

You want to digest combustible solids quickly and cleanly?

Microwave-induced oxygen combustion (MIC)

- ▶ Unique, clean and quick method.
- ▶ Halogens or metals are trapped in a low-concentration absorption solution which can be measured without dilution.
- ▶ Suitable for all combustible solids such as wood, paper, coal, food or polymers.
- ▶ Parallel combustion of up to 8 samples in highly resistant quartz vessels.
- ▶ It replaces steel combustion bombs.

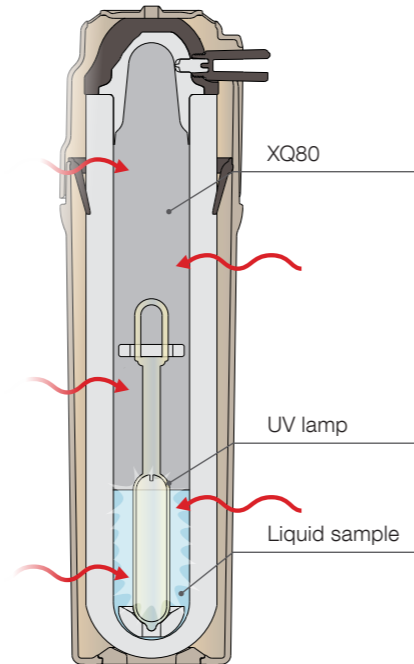

You need to digest liquid samples containing organic compounds?

UV digestion

- ▶ Unique microwave-powered UV lamps produce radicals which digest the sample.
- ▶ The resulting low-concentration solution can be measured without dilution.
- ▶ For ultra-trace analysis of e.g. seawater, effluents, sewage, body fluids or beverages.
- ▶ Low analytical blanks.

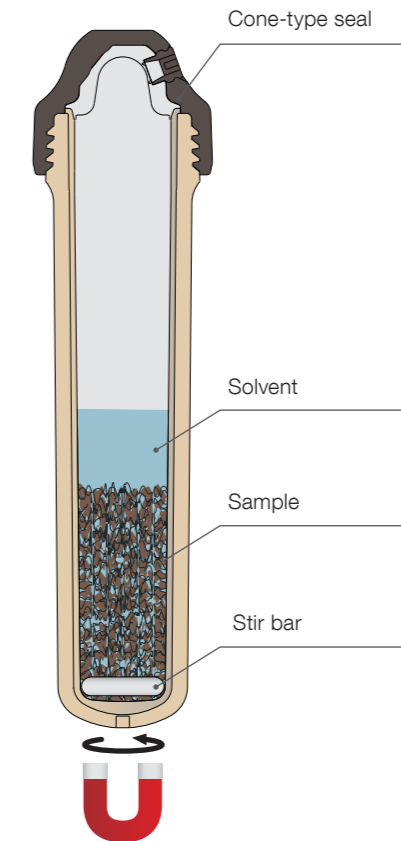

You want to extract organic compounds?

Microwave-assisted extraction

- ▶ Efficient alternative to slow and tedious solvent extraction methods.
- ▶ Improves performance and throughput of HPLC-based or GC-based analysis.
- ▶ Compliant with US-EPA and ASTM methods.
- ▶ Reduces extraction times from hours to minutes.
- ▶ Suitable for extractions of PCBs, PAHs and hydrocarbons from environmental and food samples, derivatization reactions prior to analysis and polymer extractions.

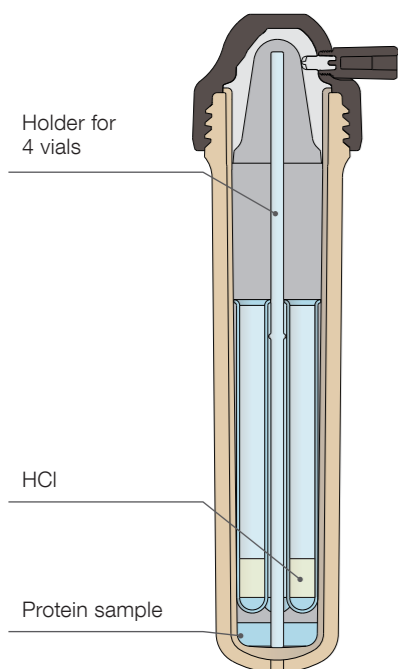

You want to run protein hydrolysis in a fraction of the time?

Microwave-assisted protein hydrolysis

- ▶ Protein hydrolysis in less than 1 hour.
- ▶ For milligram to gram amounts.
- ▶ Precise temperature control during reaction.
- ▶ Inert gas atmosphere applicable.

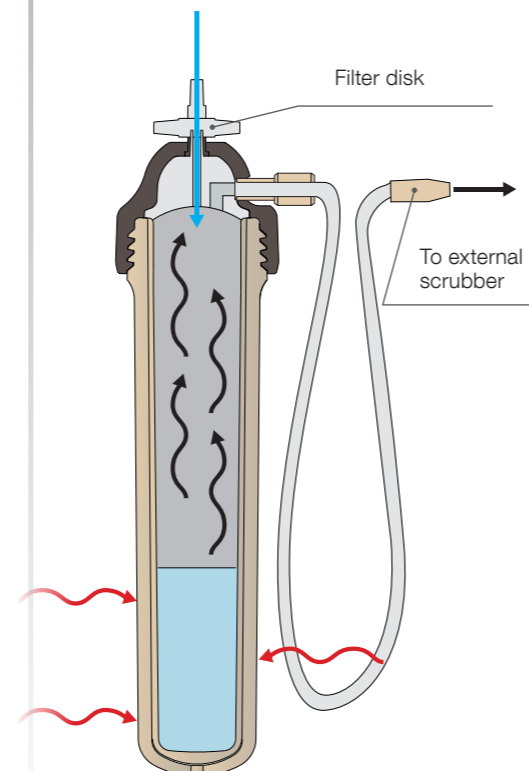

You want to accelerate your evaporation procedures?

Microwave-assisted evaporation

- ▶ Rotor 8EVAP simplifies and accelerates the microwave-assisted evaporation of acids and concentration of aqueous sample solutions.
- ▶ The external scrubber neutralizes the acid vapors, washing out up to 95 %.
- ▶ Prior to digestion, sample solutions can be concentrated to
- ▶ increase analyte levels and improve digestion efficiency.
- ▶ After evaporation, just transfer the liner into the digestion rotor.

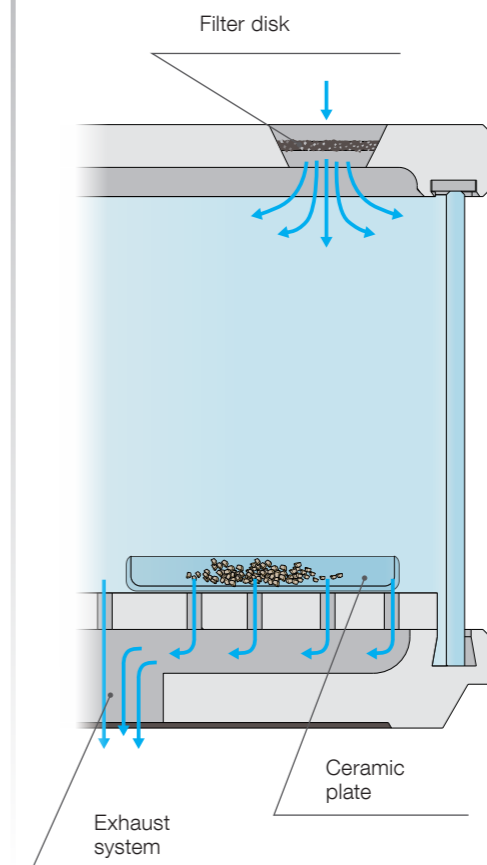

You want to dry samples before digestion?

Microwave drying

- ▶ Rotor 1DRY efficiently dries samples.
- ▶ Efficient drying: four times faster than with conventional methods.
- ▶ Provides samples without carbonization or contamination.
- ▶ Humidity and unwanted odors are removed via the exhaust system.

